



ALPHA & OMEGA GROUP
CIVIL | STRUCTURAL | WATER RESOURCES

February 17, 2026

ADDENDUM NO. 1

**RE: Engineer's Project No.: 2025.032
American Tobacco Trail Drainage Improvements**

Bid Opening Date: February 24, 2026

To Whom It May Concern:

This Addendum shall become a part of the Project Manual for the above referenced project and shall be securely attached to the front cover of the project manual.

Each bidder shall be responsible for notifying his subcontractors and/or vendors of the contents of the Addendum.

Revised or newly issued bulletin drawings (if any) contained in this Addendum shall supersede and take precedence over any conflicting information in the original drawings. Modified or newly issued sheets for the Project Manual contained in this Addendum shall supersede and take precedence over any conflicting information in the original Project Manual.

Identify all addendums on the bid proposal form. Bids not identifying addendum receipt will not be accepted for consideration.

The following changes are made to the Construction Plans:

Plan sheet C1.0:

Site 1 (Grading & Drainage), there is a tree to be removed, including the roots, located between the Bathhouse Building and the Fountain.

Plan sheet C3.0:

Site 3 (Grading & Drainage), there are (3) trees for removal along the east side driveway.

Plan sheet C4.0:

Site 4 (Grading & Drainage), there are no trees to be removed as NCDOT cut them down. There are just (3) stumps to be removed.

In South Headwall Plan: the existing sign shall be removed and delivered to the owner.

In North Headwall Plan: there are (2) existing signs that shall be removed and delivered to the owner.

The following changes are made to the Project Manual:

Section 008000 – Supplemental General Conditions, Article 1, Paragraph 1.13 insertion is revised to read:

“The Contract Time is 60 consecutive calendar days, beginning on the Date of Commencement as specified in the written Notice-to-Proceed.”

Section 011000 – Summary of Work

Add the following sentence to the end of the first paragraph of 1.3A., Site 1: “Remove 7-inch diameter Red Bud tree, including the roots, adjacent to the Bathhouse Building.

The last sentence of 1.3A., Site 3, is revised to read: “(3) trees shall be removed at this location.”

Add the following sentence to the end of the first paragraph of 1.3A., Site 4: “Remove (2) trail signs, one at each end of the tunnel, and deliver to owner for storage.”

The last sentence of 1.3A., Site 4, second paragraph is revised to read: “(2) tree stumps shall be removed at this location.

The following was discussed during the Prebid meeting:

See Pre-Bid Meeting Minutes.

The following are questions and answers for this project to date:

- Can you supply a catch basin detail. I was not able to locate this on the plans. ***There is no catch basin for this project.***
- Is there a signage detail that the County wants us to follow for the trail closure. ***The trail closure signage really will be up to you and at the work site. I do know that Wake County Parks will assist with signage of the closures as well as public notices.***

This concludes Addendum No. 1

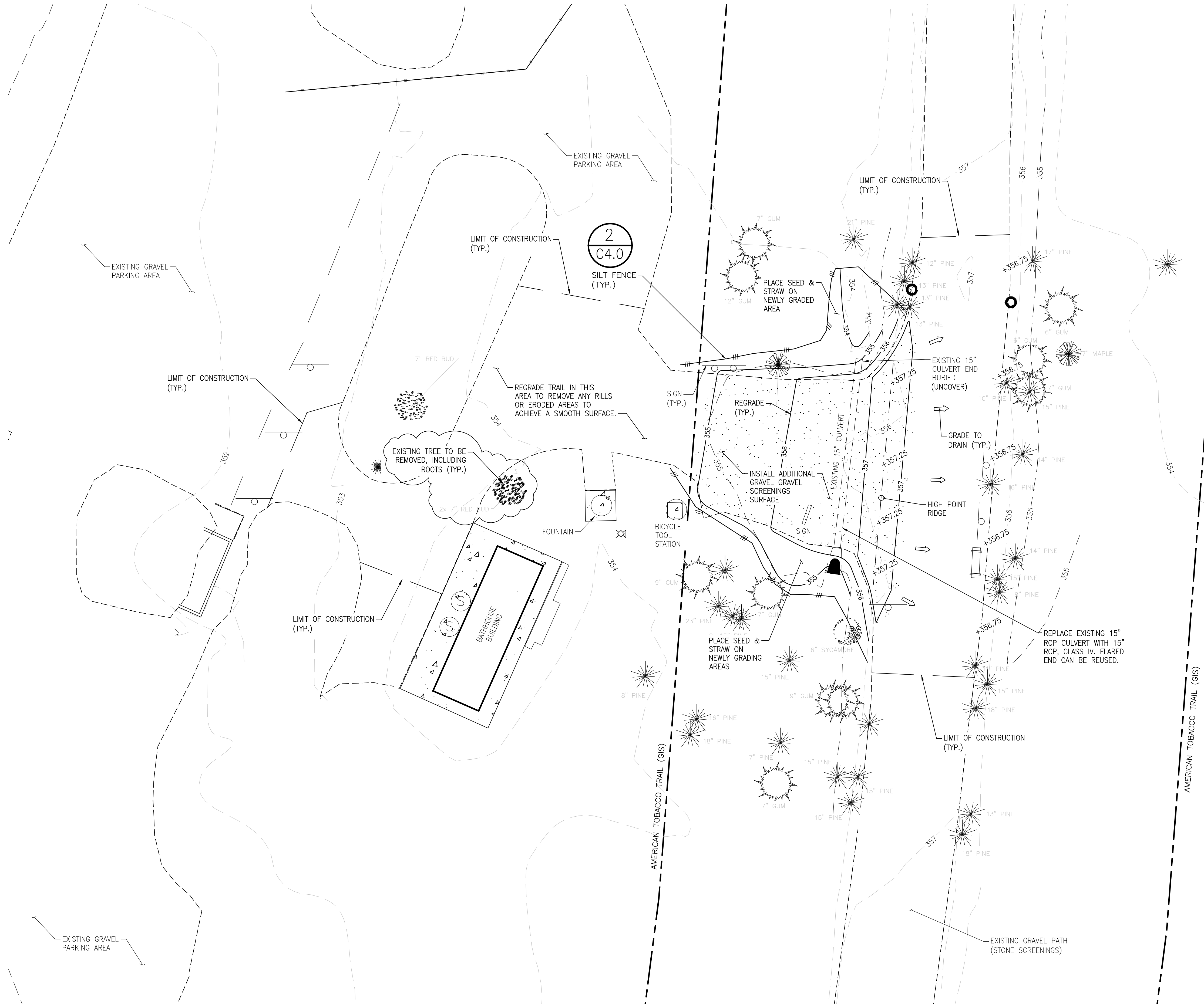

- GENERAL NOTES:**
1. ALL MATERIALS AND METHODS OF CONSTRUCTION SHALL BE IN ACCORDANCE WITH WAKE COUNTY AND/OR NCDOT STANDARDS.
 2. CONTRACTOR SHALL CONTACT NC ONE CALL BEFORE ANY DIGGING OCCURS AT 1-800-632-4949.
 3. THE CONTRACTOR SHALL CONDUCT THE WORK IN A SAFE MANNER AND WITH A MINIMUM AMOUNT OF INCONVENIENCE TO TRAFFIC.
 4. THE CONTRACTOR SHALL BE RESPONSIBLE FOR ALL TRAFFIC CONTROL AND SHALL ADHERE TO THE PROVISIONS OF THE MUTCD (MOST CURRENT EDITION).
 5. EXISTING CONDITIONS AND TOPOGRAPHICAL INFORMATION PROVIDED BY WITHERSRAVENEL DATED MAY 1, 2025. ADDITIONAL CONTOUR INFORMATION WAS ADDED TO THE PLAN FROM PUBLICLY AVAILABLE GIS DATA.
 6. ALL CONSTRUCTION SHALL CONFORM TO A.D.A STANDARDS.
 7. GENERAL CONTRACTOR SHALL VERIFY LOCATION OF ALL EXISTING UTILITIES IN ADVANCE OF CONSTRUCTION AND MAKE ANY OBSERVATIONS THAT AFFECT CONSTRUCTION KNOWN TO THE ENGINEER.
 8. GENERAL CONTRACTOR SHALL VERIFY ALL DIMENSIONS AND ELEVATIONS PRIOR TO CONSTRUCTION.
 9. ALL EXCAVATIONS SHALL BE PERFORMED IN STRICT ACCORDANCE WITH OSHA GUIDELINES (29CFR 1926, SUBPART P, EXCAVATIONS) AND OTHER LOCAL JURISDICTIONAL CODES.

LIMITS OF DISTURBANCE

TOTAL AREA WITHIN SITE 1 OF CONSTRUCTION:
5,466 SF.

LEGEND

BUILDING	
CONCRETE	
GRAVEL	
EASEMENT	
TREELINE	
CLEANOUT	
FLARED END SECTION	
SEWER MANHOLE	
WATER METER	

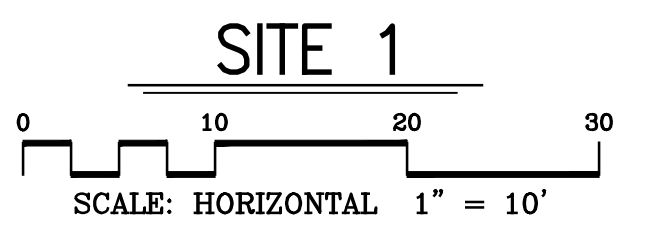

1	REVISED PER WAKE COUNTY REVIEW	08/26/2025
2	REVISED PER COMMENTS DURING PRE-BID MEETING (SEE SHT. C3.0 AND C4.0)	02/10/2026
No.	Description: Revision	Date:

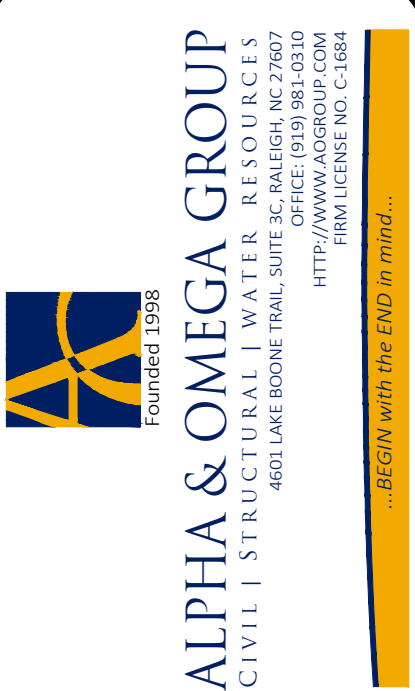

**AMERICAN TOBACCO TRAIL
DRAINAGE IMPROVEMENTS
WAKE COUNTY, NORTH CAROLINA**

**GRADING & DRAINAGE
SITE 1
MILE MARKER 17.50**

Project No.: **2025.032**
 Issued For: **CONSTRUCTION**
 Issued Date: **01/27/2026**

Drawn By: **YTM**
 Checked By: **WSN**
 Sheet No.: **C1.0**

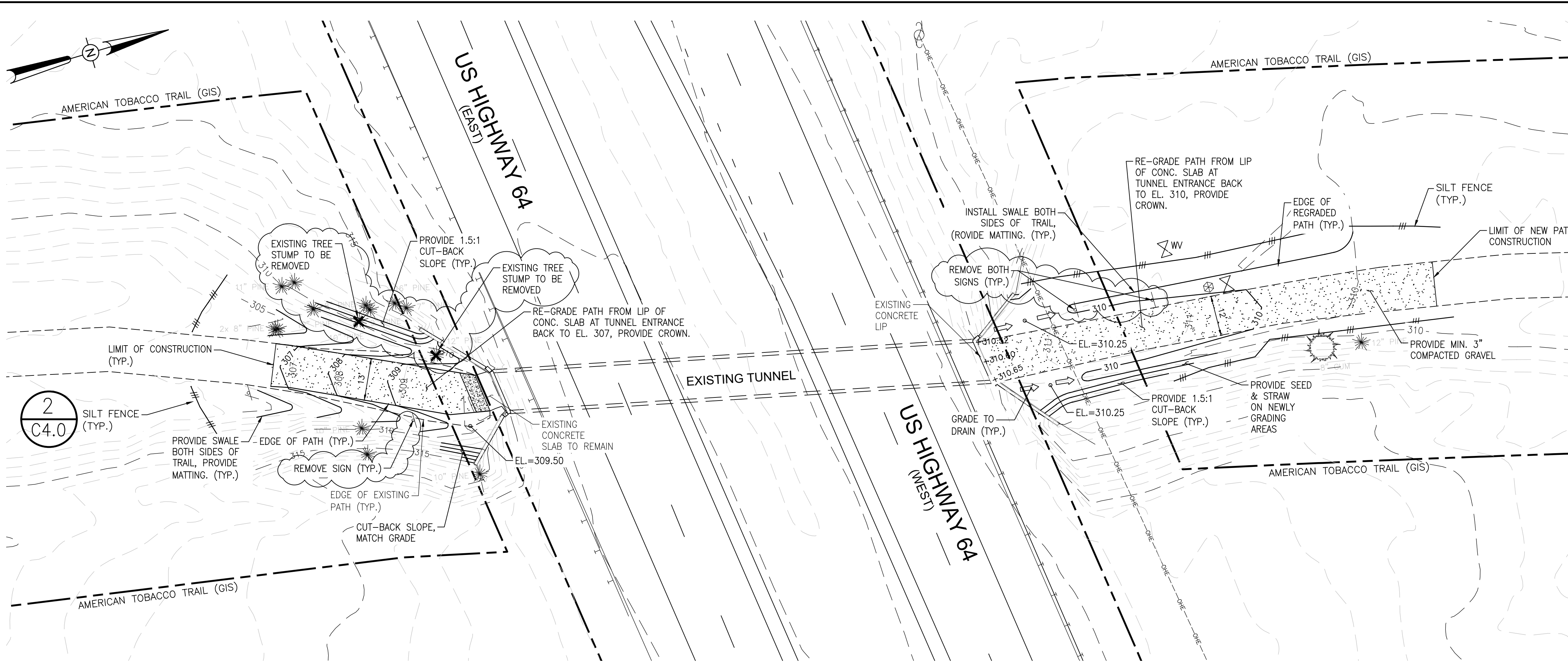

SITE 4
 SCALE: HORIZONTAL 1" = 20'

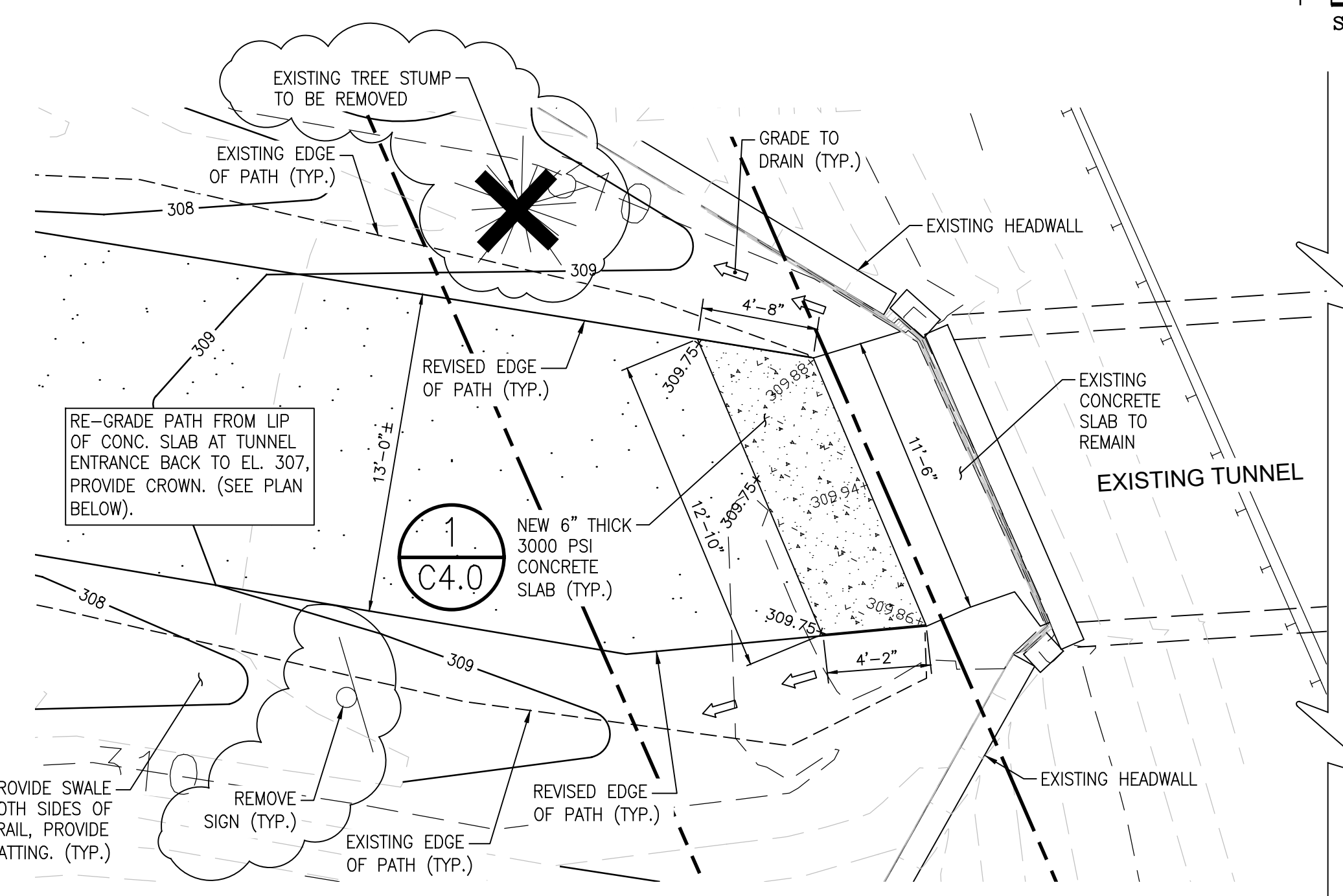

SOUTH HEADWALL PLAN
 SCALE: HORIZONTAL 1" = 5'

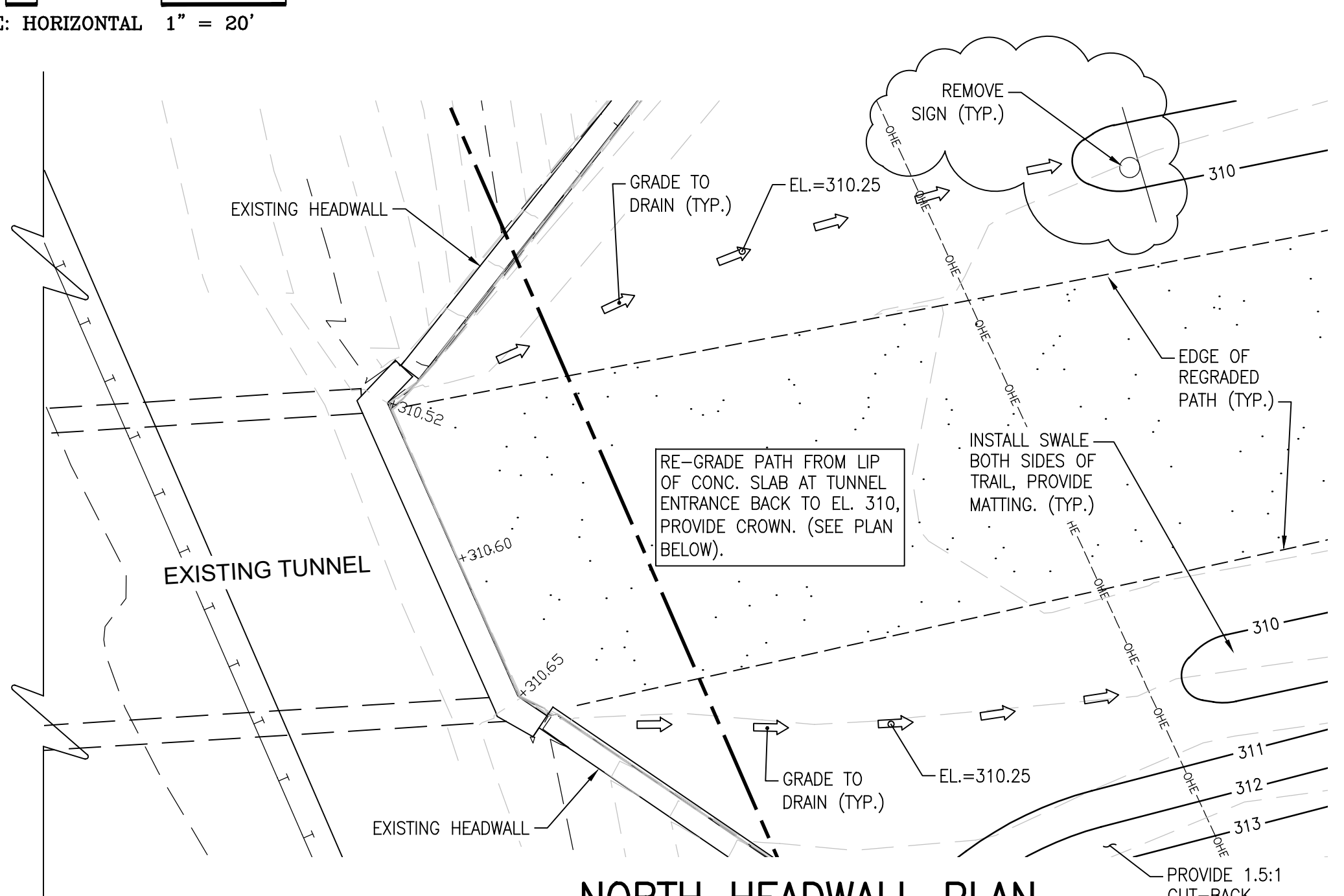

NORTH HEADWALL PLAN
 SCALE: HORIZONTAL 1" = 5'

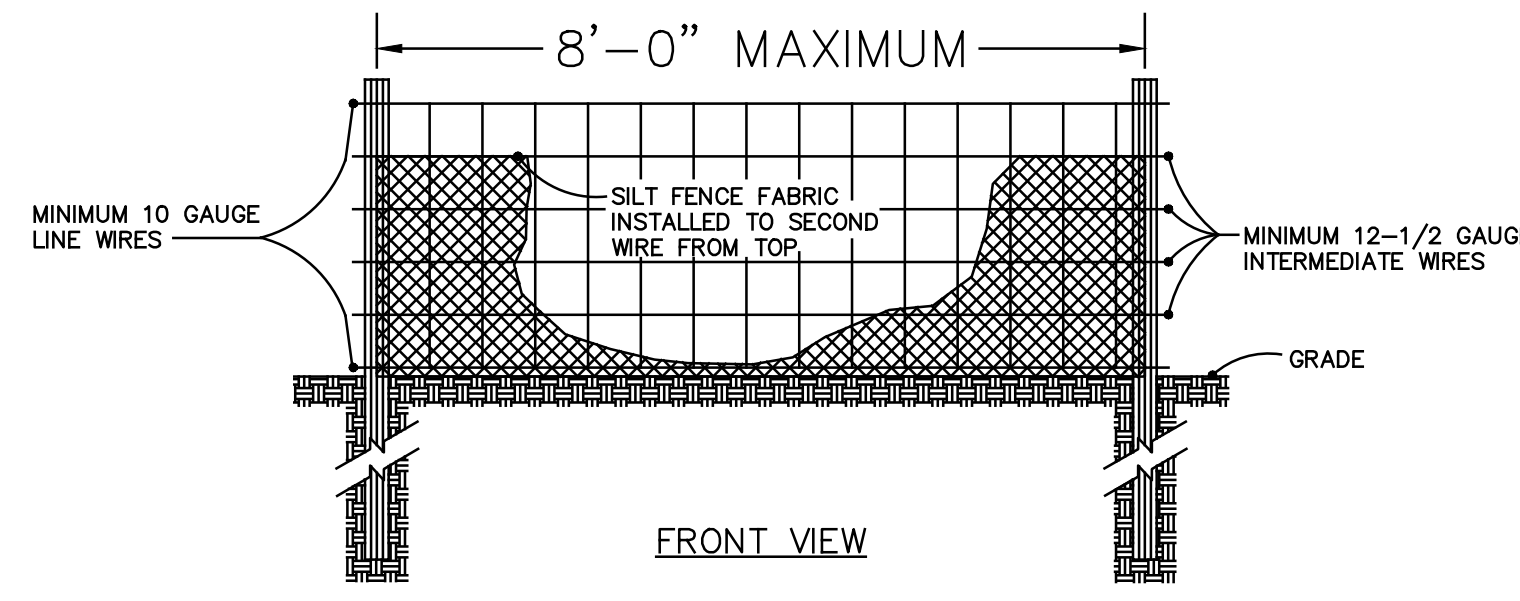

FRONT VIEW

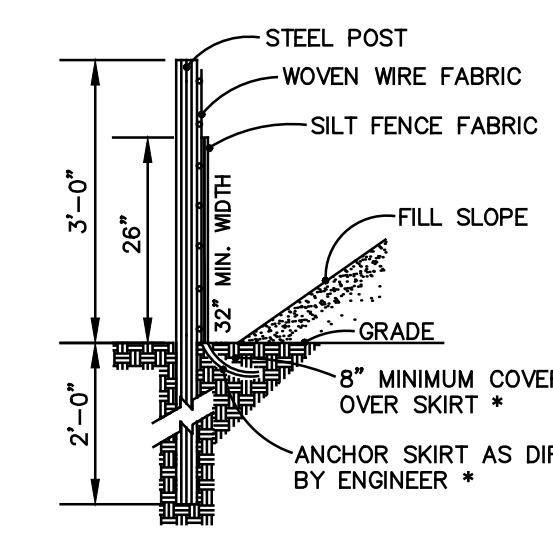

SIDE VIEW

MAINTENANCE NOTES:

1. INSPECT BAG AFTER EACH SIGNIFICANT RAINFALL OF 1 INCHES OR GREATER, OVER A 24-HOUR PERIOD. MAKE ANY REPAIRS IMMEDIATELY.
2. INSPECT THE SILT FENCE TO BE SURE THE BOTTOM OF THE GEOTEXTILE IS KEYED IN PROPERLY.
3. AT A MINIMUM, REMOVE AND DISPOSE OF ALL SILT ACCUMULATIONS WHEN DEPTH REACHES 1/2 THE HEIGHT OF THE GEOTEXTILE. DO NOT UNDERMINE THE FENCE DURING CLEANOUT.
4. DISPOSE OF SEDIMENT BY HAULING IT TO AN APPROVED WASTE SITE WITH APPROPRIATE PERMETER PROTECTION.
5. REMOVE AND REPLACE DETERIORATED OR CLOGGED SILT FENCE.
6. REPLACE SILT FENCE REMOVED FOR ACCESS AT THE END OF EACH DAY'S OPERATION.
7. INSTALL ADDITIONAL POSTS OR WIRE BACKING IF FENCE IS SAGGING.

2 TEMPORARY SILT FENCE DETAIL
 SCALE: N.T.S.

LIMITS OF DISTURBANCE
 TOTAL AREA WITHIN SITE 4 OF CONSTRUCTION:
 7,102 SF.

MATERIALS:

- 28 DAY COMPRESSIVE STRENGTH SLAB ON GRADE F_c = 3000 PSI
- WELDED WIRE FABRIC ASTM 185

LEGEND (UNLESS OTHERWISE NOTED)

- CONCRETE
- GRAVEL
- RETAINING WALL
- MONITORING WELL SIGN
- SEWER MANHOLE
- WATER METER
- WATER VALVE
- EXISTING SPOT ELEV. +310.60
- NEW SPOT ELEV. +309.75

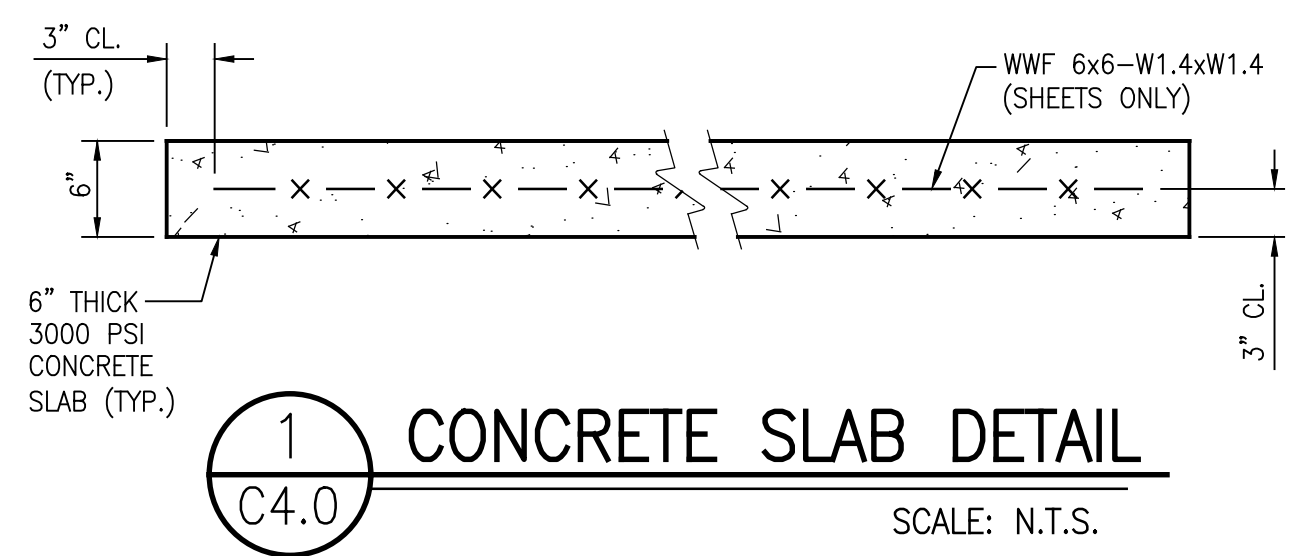

1 CONCRETE SLAB DETAIL
 SCALE: N.T.S.

GENERAL NOTES:

1. ALL MATERIALS AND METHODS OF CONSTRUCTION SHALL BE IN ACCORDANCE WITH WAKE COUNTY AND/OR NCDOT STANDARDS.
2. CONTRACTOR SHALL CONTACT NC ONE CALL BEFORE ANY DIGGING OCCURS AT 1-800-632-4949.
3. THE CONTRACTOR SHALL CONDUCT THE WORK IN A SAFE MANNER AND WITH A MINIMUM AMOUNT OF INCONVENIENCE TO TRAFFIC.
4. THE CONTRACTOR SHALL BE RESPONSIBLE FOR ALL TRAFFIC CONTROL AND SHALL ADHERE TO THE PROVISIONS OF THE MUTCD (MOST CURRENT EDITION).
5. EXISTING CONDITIONS AND TOPOGRAPHICAL INFORMATION PROVIDED BY WITHERSRAVENEL DATED MAY 1, 2025. ADDITIONAL CONTOUR INFORMATION WAS ADDED TO THE PLAN FROM PUBLICLY AVAILABLE GIS DATA.
6. ALL CONSTRUCTION SHALL CONFORM TO A.D.A STANDARDS.
7. GENERAL CONTRACTOR SHALL VERIFY LOCATION OF ALL EXISTING UTILITIES IN ADVANCE OF CONSTRUCTION AND MAKE ANY OBSERVATIONS THAT AFFECT CONSTRUCTION KNOWN TO THE ENGINEER.
8. GENERAL CONTRACTOR SHALL VERIFY ALL DIMENSIONS AND ELEVATIONS PRIOR TO CONSTRUCTION.
9. ALL EXCAVATIONS SHALL BE PERFORMED IN STRICT ACCORDANCE WITH OSHA GUIDELINES (20CFR 1926, SUBPART P, EXCAVATIONS) AND OTHER LOCAL JURISDICTIONAL CODES.

1	REVISED PER WAKE COUNTY REVIEW	08/26/2025
2	REVISED PER COMMENTS DURING PRE-BID MEETING (SEE SHT. C3.0 AND C4.0)	02/10/2026
No.	Description: Revision	Date:



ALPHA & OMEGA GROUP
 CIVIL STRUCTURAL WATER RESOURCES
 4601 LAKE BOONE TRAIL, SUITE 300, RALEIGH, NC 27607
 HTTP://WWW.ALPHAOEGROUP.COM
 PIANO LICENSE NO. C. 1084

PROFESSIONAL SEAL
 WILLIAM S. MEDLAND
 ENGINEER
 SEAL 031746
 Signed by: **Bill Medland, PE**
 8007048074@AEC

AMERICAN TOBACCO TRAIL DRAINAGE IMPROVEMENTS
 WAKE COUNTY, NORTH CAROLINA

Project Title:

GRADING & DRAINAGE
 SITE 4
 MILE MARKER 20.00
 3" CL.

Sheet Title:

Project No.: **2025.032**
 Issued For: **CONSTRUCTION**
 Issued Date: **01/27/2026**

Drawn By: **YTM**
 Checked By: **WSN**
 Sheet No.: **C4.0**

SUPPLEMENTARY GENERAL CONDITIONS

GENERAL

This Supplementary Conditions contains changes and additions to the project "GENERAL CONDITIONS OF THE CONTRACT FOR CONSTRUCTION", as published herein. Where any Article of the General Conditions is modified or any Paragraph, Subparagraph or Clause thereof is modified or deleted by these Supplementary Conditions, the unaltered provisions of the Article, Paragraph, Subparagraph or Clause shall remain in effect.

ARTICLE 1. Definitions

Paragraph 1.13: At the end of the existing paragraph, add the following:

“The Contract Time is **60 consecutive calendar days**, beginning on the Date of Commencement as specified in the written Notice-to-Proceed.” Due to the periodic use of the facility, construction activities will be required to be coordinated with park staff for access to the facility during the construction period.

Contractor shall accommodate his schedule to perform the work in such a way to not impact planned events at the American Tobacco Trail. Such events are scheduled as follows: March 14th, March 28th, and April 24th and 25th, 2026, allow 2 days before each date for event set up.

Paragraph 1.17: Add the following:

“The Designer/Firm for this contract is: Alpha & Omega Group
4601 Lake Boone Trail, Suite 3C
Raleigh, NC 27607 (919) 981-0310

Paragraph 1.18: Delete the last sentence in its entirety and substitute the following in lieu thereof:

“A list of the Drawings is contained in the “Supplementary General Conditions.”

The Drawings applicable to this Contract are as follows:

CVR Cover Sheet
C0.0 Site Index Plan
C1.0 Grading & Drainage Site 1 Mile Marker 17.50
C2.0 Grading & Drainage Site 2 Mile Marker 17.75
C3.0 Grading & Drainage Site 3 Mile Marker 18.75
C4.0 Grading & Drainage Site 4 Mile Marker 20.00
C5.0 Grading & Drainage Site 5 Mile Marker 21.50
C6.0 Grading & Drainage Site 6 Mile Marker 22.00

Paragraph 1.27: Add the following:

“Owner’s Authorized Representative:

Project Manager: Paulo G. Lopez
Wake County Facilities Design & Construction
P.O. Box 550
Raleigh, NC 27602
(919) 856-6351

Paragraph 1.29: Add the following:

“The Project is titled “American Tobacco Trail Drainage Improvements”. All required papers shall be delivered to the Project Manager listed above unless otherwise directed in writing to the Contractor.”

ARTICLE 3. Familiarity with Work, Conditions and Laws

Paragraph 3.3: Add the following:

“All Project Work shall conform to the regulations, codes, and standards of the following institutions or agencies:

American National Standards Institute (ANSI)
American Society of Testing and Materials (ASTM)
American Welding Society (AWS)
North Carolina State Building Code (NCSBC)
North Carolina Division of Environmental Health (DEH)
Occupational Safety and Health Act (OSHA)”

ARTICLE 6. Other Record Documents and Submittals

Paragraph 6.1: At the end of the existing paragraph, add the following:

“Electronic copies of the Contract Documents will be furnished to the General Contractor.”

ARTICLE 10. Designer

Add the following paragraphs:

“10.5 As a part of its Basic Services under the Owner-Designer Agreement, the Designer will conduct a single site visit to determine Substantial Completion of the Work.

If, after the performance of said site visit, the Designer determines that the Work is not substantially complete, successive site visits to determine Substantial

Completion will be deemed Additional Services under the Owner-Designer Agreement. The Contractor shall be liable to the Owner for any Designer's fees incurred as a result of any such Additional Services of the Designer. Any funds due under this paragraph may be deducted by the Owner from the amounts due the Contractor for such additional Designer's fees and paid directly to the Designer. Should the cost for such Additional Services of the Designer exceed the amount due or to become due to the Contractor, then the Contractor and his sureties shall be liable for and shall pay to the Owner the amount of any such excess.

“10.6 As a part of its Basic Services under the Owner-Designer Agreement, the Designer will conduct a single site visit to determine Final Completion of the Work. If, after the performance of said site visit, the Designer determines that the Work is not complete, successive site visits to determine Final Completion of the Work will be deemed Additional Services under the Owner-Designer Agreement. The Contractor shall be liable to the Owner for any Designer's fees incurred as a result of any such Additional Services of the Designer. Any funds due under this paragraph may be deducted by the Owner from the amounts due the Contractor for such additional Designer's fees and paid directly to the Designer. Should the cost for such Additional Services of the Designer exceed the amount due or to become due to the Contractor, then the Contractor and his sureties shall be liable for and shall pay to the Owner the amount of any such excess.”

ARTICLE 13. Contract Time

Paragraph 13.1: The existing paragraph is revised to read as follows:

Within fourteen (14) days after receipt of the Construction Agreement by the Contractor for signatures, the Project Expediter shall prepare and submit to the Designer and Owner for review and approval a **coordinated construction** schedule for the Work pursuant to the requirements stated in the Contract Documents.

Paragraph 13.18: Add the following:

“If the Contractor fails to achieve Substantial Completion of the Work within the Contract Time and as otherwise required by the Contract Documents, the Owner shall be entitled to retain or recover from the Contractor, as Step One Liquidated Damages and not as a penalty, the following per diem amount commencing upon the first day following expiration of the Contract Time and continuing until the actual date of Substantial Completion. Such liquidated damages are hereby agreed to be a reasonable pre-estimate of damages the Owner will incur as a result of delayed Substantial Completion of the Work:

Two Hundred Dollars (\$200.00) per consecutive calendar day

If the Contractor fails to achieve Final Completion of the Work within thirty (30) consecutive calendar days of the actual date of Substantial Completion of the Work, the Owner shall be entitled to retain or recover from the Contractor, as Step Two Liquidated Damages and not as a penalty, the following per diem amount commencing upon the first day following the actual date of Substantial Completion and continuing until the actual date of Final Completion. Such liquidated damages are hereby agreed to be a reasonable pre-estimate of damages the Owner will incur as a result of delayed Final Completion of the Work:

One Hundred Dollars (\$100.00) per consecutive calendar day

The Owner may deduct liquidated damages described above from any unpaid amounts then or thereafter due the Contractor under this Agreement. Should the amount of any liquidated damages exceed the amount due or to become due to the Contractor, then the Contractor and his sureties shall be liable for and shall pay to the Owner the amount of any such excess.”

ARTICLE 29. Taxes

Paragraph 29.1: Add the following to the existing paragraph:

“The Contractor is to use the Sales Tax Reporting Form attached to Section 012900 of the contract documents for reporting taxes paid.”

ARTICLE 35. Minority Business Enterprise Program

The MBE program is not required for this project.

ARTICLE 36. General

Add the following paragraph:

“36.3 Any specific requirement in this Contract that the responsibilities or obligations of the Contractor also apply to a Subcontractor is added for emphasis and is also hereby deemed to include a Subcontractor of any tier. The omission of a reference to a Subcontractor in connection with any of the Contractor’s responsibilities or obligations shall not be construed to diminish, abrogate, or limit any responsibilities or obligations of a Subcontractor of any tier under the Contract Documents or the applicable subcontract.”

END OF SUPPLEMENTARY GENERAL CONDITIONS

SECTION 011000 – SUMMARY OF WORK

PART 1 - GENERAL

1.1 SUMMARY

A. Section Includes:

1. Project information.
2. Work covered by Contract Documents.
3. Access to site.
4. Coordination with occupants.
5. Work restrictions.
6. Specification and Drawing conventions.

- B. All work at the American Tobacco Trail Drainage Improvements will be bid according to the laws and regulations applicable to the Construction of Public Facilities and the Laws and Regulations applicable to Contracting in the State of North Carolina.

1.2 PROJECT INFORMATION

- A. Project Identification: “American Tobacco Trail Drainage Improvements”, Engineer’s Project Number 2025.032
- B. Owner #1: Wake County Parks, Recreation & Open Space
601 W. Third Street, Raleigh, NC 27603
PO Box 550
Raleigh, NC 27602

1. Owner's Representative:

Project Manager: Paulo G. Lopez
Wake Co. Facilities, Design, and Construction
Wake County Office Bldg., 11th Floor
Raleigh, NC 27602
(919) 856-6351

1.3 WORK COVERED BY CONTRACT DOCUMENTS

- A. The Work of Project is defined by the Contract Documents and consists of the following:

Site 1 – Mile Marker 17.50: Regrade an area approx. 5,000 SF of the trail system and parking lot access around the bathrooms at the White Oak Church Road parking area. Culvert repair or replacement is included with this site. Remove 7-inch diameter Red Bud tree, including the roots, adjacent to the Bathhouse Building.

Site 2 – Mile Marker 17.75: Install catchment basin along trail edge and regrade an area approx. 2,100 SF of the trail system at a drainage outfall approx. 0.33 mile south of the White Oak Church Road crossing. Several trees shall be removed at this location.

Site 3 – Mile Marker 18.75: Regrade an area approx. 2,200 SF of the trail system and private access that crosses the trail approx. 0.38 mile south of the Wimberly Road crossing. Culvert repairs or replacements and ditch line grading is included with this site. The uphill access road will receive 4” of compacted ABC, and both shoulders and ditch grading along the access with seeding and matting. (3) trees shall be removed at this location.

Site 4 – Mile Marker 20.00: Regrade the trail at both ends of the highway tunnel. North end of the tunnel has an area of approx. 3,000 SF that will include cutting the trail down approx. 1 to 2 FT in elevation and supplementing the trail surfacing with 3 inches of compacted gravel screenings. Shoulder and ditch grading work will be needed along trail edges with seeding and matting. Remove (2) trail signs, one at each end of the tunnel, and deliver to owner for storage.

South side of the tunnel has an area approx. 2,500 SF that will include shoulder and ditch grading work will be needed along trail edges with seeding and matting. A concrete approach slab will be constructed approx. 50 SF by 6 inches deep that shall be placed next to the existing slab at the tunnel exit. Several trees shall be removed at this location. (2) tree stumps shall be removed at this location.

Site 5 – Mile Marker 21.50: Install catchment basin along both sides of the trail edges and regrade an area approx. 3,900 SF of the trail system at a drainage outfall approx. 0.30 mile north of the New Hill Parking Area. A 30 FT section of HDPE pipe will be installed and the ditch at both ends will be lined with rip rap. Several trees shall be removed at this location.

Site 6 – Mile Marker 22.00: Regrade approx. 0.35 Acre of the New Hill Parking Area along the southeast side. Parking area will be compacted and ditch grading work will be needed for parking lot runoff.

B. Type of Contract:

1. Project will be constructed under a single prime contract.

1.4 ACCESS TO SITE

- A. General: Contractor shall have limited use of Project site for construction operations as indicated on Drawings by the Contract limits and as indicated by requirements of this Section.
- B. Use of Site: Limit use of Project site to Work in areas indicated. Do not disturb portions of the Project site beyond areas in which the Work is indicated.

1. Driveways, Walkways, and Entrances: Keep entrances and access roads serving premises clear and available to the Owner, Owner's employees, and emergency vehicles always. Do not use these areas for parking or for storage of materials.

1.5 COORDINATION WITH OCCUPANTS

- A. Partial Owner Occupancy: Owner will occupy the premises during the entire construction period, apart from areas under construction. Cooperate with Owner during construction operations to minimize conflicts and facilitate Owner usage. Perform the Work so as not to interfere with Owner's operations. Maintain existing exits unless otherwise indicated.

1.6 WORK RESTRICTIONS

- A. Work Restrictions, General: Comply with restrictions on construction operations.
 1. Comply with limitations on the use of public streets and with other requirements of authorities having jurisdiction.
- B. On-Site Work Hours: Limit work to normal business working hours from 7:00 a.m. to 7:00 p.m., Monday through Friday, unless otherwise indicated.
- C. Restricted Substances: Use of tobacco products and other controlled substances on Project site is not permitted.
- D. Contractor shall coordinate his schedule to perform the work in such a way to not impact planned events at the American Tobacco Trail. Such events are scheduled as follows:
 1. March 14th Marathon, March 28th Race, and April 24th and 25th, 2026 10 mile race. Allow 2 days before each date for event set up.

PART 2 - PRODUCTS (Not Used)

PART 3 - EXECUTION (Not Used)

END OF SECTION 011000



ALPHA & OMEGA GROUP
CIVIL | STRUCTURAL | WATER RESOURCES

American Tobacco Trail Drainage Improvements

Date: February 10, 2026

Time: 10:00 am (Eastern)

Location: 1309 New Hill-Olive Chapel Rd.
Apex, NC 27502

PRE-BID MEETING MINUTES

Attendees: see sign in sheet

1. INTRODUCTIONS:
 - Forrest Robbins - A&O Group (Project Manager)
 - William S. Needham, PE – A&O Group (EOR)
 - Paulo G. Lopez – Project Manager (Owner)
 - Ashley Subat – Park Manager (Owner)
 - *Steve McMurry – Assist. Park Manager (Owner)*
2. BIDDING INSTRUCTIONS
 - Construction Contract: Informal
 - Addendums shall be noted on the Bid Proposal Form.
 - A Bid Security of 5% is required for this project.
 - Performance and Payment Bonds are required.
 - Contract time: 40 consecutive calendar days. *Contractors expressed concerns about contract time. Thought were that it should be 60 days as a minimum.*
 - Bid date: close on Tuesday February 24, 2026, at 2:00 pm local time.
 - Last day for questions: 12:00 p.m., Wednesday, February 18, 2026.
3. SUMMARY OF WORK
 - Review “Summary of Work” Sec. 11000, 1.3 *This section was reviewed at each site visit.*
 - Review Plans
 - Access to site *Owner requests avoiding work on weekends due to the amount of public use.*
 - Coordination with Owner & Hours of Operation. *Trail hours are from 8:00 am to dusk but the public has access to the trail outside those hours.*
4. QUESTIONS:
 - *The contractor will have to provide Notice to the Public in advance of any trail closures. Owner requests coordination of closures regarding excavation of cross culverts and tree cutting.*
 - *The trail events were discussed as the contractor will have to suspend work during these times. (Event dates are listed at the end of Sec. 011000 Summary of Work)*
 - *Changes at Site 1, Site 3, and Site 4 will be sent out as an addendum. Some of the trees to be cut down at Site 3 have been cut down by NCDOT. Stump removal and sign removal will take place instead. At Site 4 a couple additional trees identified to be included for removal. Site 1 was for the removal of a 6-inch Red Bud tree adjacent to the bathhouse.*
 - *The contractor shall maintain signs and barricades to separate the public from the work site.*
 - *An addendum with discussed changes will follow this meeting.*

American Tobacco Trail Drainage Improvements

Project No. 2025.032

02/10/26

Name	Company	Phone	Email
EARL GILL	PGA	919-545-1744	
TIM REESE	PGA	919-610-1260	PGAConstruction@Aol.com
Ash Sobat	Wake County - H&C/PLATT	919-387-4326	ashley_sobat@wake.gov
BJ Lanier	Lanier Construction	252-286-6739	bj@lanier.construction.com
Daniel Belton	Lanier Construction	984-379-2207	Daniel@lanierconstruction.com
Bruce Hollis	White Oak Const. Corp.	919-868-8020	
Paul Lopez	Wake County		
Steve McMurry	Wake County		
Forrest Robbins	A+O Group	919 981 0310 xt109	forrobbs@aogroup.com
Bill NEEDHAM	"	" " " x111	w3needham@ayg.com